

MULTI-CHANNEL NOISE REDUCED VISUAL EVOKED POTENTIAL ANALYSIS

Non-member Ramaswamy Palaniappan (Multimedia University, Malaysia)
 Non-member Paramesran Raveendran (University of Malaya, Malaysia)
 Member Shogo Nishida (Osaka University, Japan)

In this paper, Principal Component Analysis (PCA) is used to reduce noise from multi-channel Visual Evoked Potential (VEP) signals. PCA is applied to reduce noise from multi-channel VEP signals because VEP signals are more correlated from one channel to another as compared to noise during visual perception. Emulated VEP signals contaminated with noise are used to show the noise reduction ability of PCA. These noise reduced VEP signals are analysed in the gamma spectral band to classify alcoholics and non-alcoholics with a Fuzzy ARTMAP (FA) neural network. A zero phase Butterworth digital filter is used to extract gamma band power in spectral range of 30 to 50 Hz from these noise reduced VEP signals. The results using 800 VEP signals give an average FA classification of 92.50% with the application of PCA and 83.33% without the application of PCA.

Keywords: Alcoholics, Fuzzy ARTMAP, Gamma band, Object recognition, Principal component analysis, Visual stimulus

1. INTRODUCTION

Evoked potential is typically generated in response to external stimulus. The application of sensory stimulus like visually seeing a set of pictures gives rhythmic Visual Evoked Potential (VEP), which is the coupled and coherent activity of an ensemble of neuronal generators in the brain⁽²⁾ Over the years, VEP analysis has become very useful for neuropsychological studies and clinical purposes⁽⁸⁾. Specifically, the effects of alcohol on the central nervous system of humans and genetic predisposition towards alcoholism have been studied using evoked responses^{(12) (3)}.

The VEP signal is embedded in the ongoing electroencephalogram (EEG) with additive noise causing difficulty in detection and analysis of this signal. The traditional technique of reducing this EEG contamination is to use ensemble averaging⁽¹⁾. However, this approach requires many trials and the averaged signal might tend to smooth out inter-trial information. Furthermore, it leads to system complexity and higher computational time.

In this paper, a zero phase Butterworth digital filter is used to extract gamma band spectral power of single trial VEP signals buried in the spontaneous EEG activity. Our method assumes that the ratio of VEP to EEG is higher in the gamma band range, thereby circumventing methods like signal averaging to improve the VEP/EEG ratio. This assumption follows research of single trial gamma band VEP signals used to study stimulus specificity of visual responses in humans⁽¹¹⁾. In addition, it is reported that gamma band spectra centred at 40 Hz is evoked during the application of

sensory simulation⁽²⁾.

Principal Component Analysis (PCA) is a technique commonly employed to reduce the dimension of the feature set⁽⁵⁾. In this paper, PCA is applied to reduce noise effects in VEP. VEP signals are more correlated from one channel to another as compared to noise during visual perception. As such, PCA which uses eigen analysis of data covariance matrix can be applied to reduce noise in VEP signals.

Parseval's theorem is used to obtain the spectral power of the filtered signal in time domain. Since the entire computation of the features remain in time domain, this method is efficient than methods requiring power spectrum computation like periodogram analysis. The extracted spectral power values are used to classify alcoholics and non-alcoholics using a simplified Fuzzy ARTMAP (FA) neural network (NN) classifier developed by Kasuba⁽⁶⁾.

2. NOISE REMOVAL USING PCA

PCA⁽⁵⁾ is applied to remove noise from the VEP data. The extracted VEP signals consist of two parts: signal and noise. Therefore, using PCA, it is possible to separate noise from signal using the fact that the noise subspace will constitute of principal components (PCs) with eigenvalues chosen below a certain threshold and eigenvalues with PCs above this threshold represent the signal subspace. Assuming matrix x to represent the extracted noise corrupted VEP signal, the covariance of matrix x is computed using:

$$R = E(xx^T) \dots\dots\dots(1)$$

Next, matrices E and D , are computed where E is

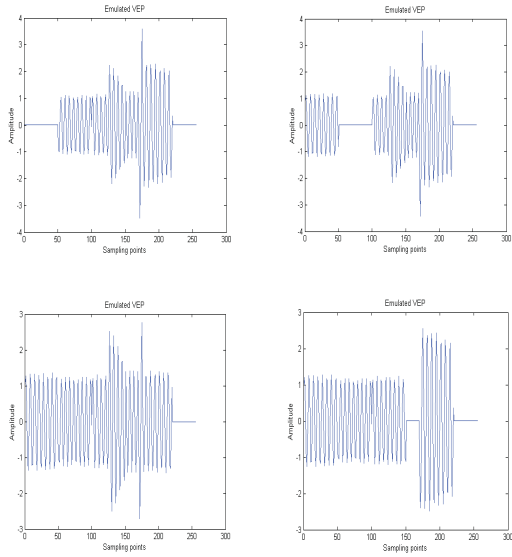

Fig. 1. Emulated VEP signals

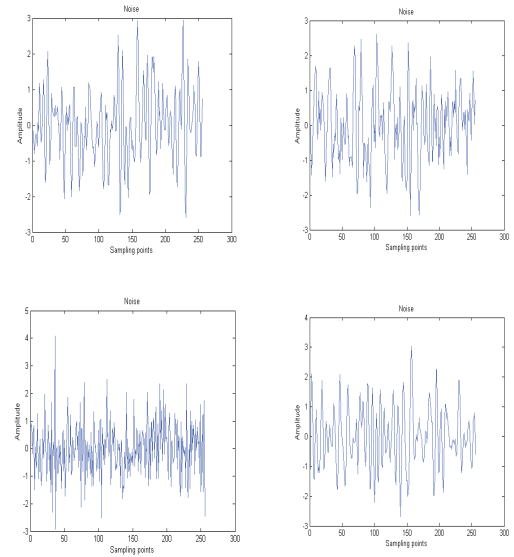

Fig. 2. Whitened noise signals

the orthogonal matrix of eigenvectors of R and D is the diagonal matrix of its eigenvalues, $D = \text{diag}(d_1, \dots, d_n)$. The PCs can now be computed using

$$y = E^T x^T \dots \dots \dots (2)$$

In this work, Kaiser's rule is used to give the number of required PCs⁽⁵⁾. Using this method, PCs with eigenvalue more than 1.0 are considered to be part of the signal subspace. The signal part of the EEG can now be reconstructed from the selected PCs using

$$\hat{x} = \hat{E} \hat{y} \dots \dots \dots (3)$$

where \hat{E} and \hat{y} are the eigenvectors and PCs corresponding to eigenvalues less than 1.0.

2.1 Simulation Study A simulation study is conducted using emulated VEP signals contaminated with noise. The study is used to show that PCA could considerably reduce noise effects from the emulated VEP signals. VEP signal is emulated using a combination of 5 randomly selected waveforms from 6 basic waveforms, each with different frequency and amplitude. The emulated VEP signals are later normalised to zero mean and unit variance. The basic waveform equation is:

$$G(n) = A \sin\left(\frac{2\pi n f}{f_s}\right) \dots \dots \dots (4)$$

where f is the frequency in the gamma band range (randomly selected from 30-50 Hz), f_s is the sampling frequency (256 Hz), and A is the amplitude of the signal. The amplitude is chosen randomly in the range of 20 ~ 30 units. This variation in the amplitude and frequency are to emulate the real VEP signals. Some of the emulated VEP signals are shown in Figure 1.

The noise is constructed using whitening method, which is as follows. EEG signals are extracted while

the subjects are at rest. These signals are first centred to remove the mean and then whitened to remove correlation between its components and to achieve unit variance. Assuming matrix z to represent the extracted signal, whitening seeks to obtain noise matrix \tilde{z} , where the covariance of matrix \tilde{z} equals the identity matrix:

$$E(\tilde{z}\tilde{z}^T) = I \dots \dots \dots (5)$$

A common whitening method is to use the eigenvalue decomposition of the covariance matrix $E(\tilde{z}\tilde{z}^T) = EDE^T$, where E is the orthogonal matrix of eigenvectors of $E(\tilde{z}\tilde{z}^T)$ and D is the diagonal matrix of its eigenvalues, $D = \text{diag}(d_1, \dots, d_n)$. Whitening can now be achieved using

$$\tilde{z} = ED^{-\frac{1}{2}}E^T z \dots \dots \dots (6)$$

Some of the whitened noise signals are shown in Figure 2.

The VEP signal with noise artifact can now be constructed using

$$x(n)_{\text{noise+VEP}} = x(n)_{\text{VEP}} + x(n)_{\text{noise}} \dots \dots \dots (7)$$

The signal to noise (SNR) of VEP signal is set approximately to -9 dB, i.e. the signal level is approximately 1/3 of the noise level. Sixty-one emulated VEP signals contaminated with noise are created and PCA is applied. Using Kaiser's rule, the number of PCs to reconstruct the data can be determined. Kaiser's rule is more suitable for automated procedures as compared to other methods like scree graph test since it does not involve manual inspection. Using this method, the first 6 PCs are selected for reconstruction.

The first column of Figure 3 shows the emulated VEP signals. The noise contaminated VEP signals are shown in the second column while the third column shows the

Table 1. SNR values of VEP signals in the simulation study

Signal	SNR		
	Without PCA	With PCA	SNR improvement
1	-8.64	-4.35	4.29
2	-9.31	-4.27	5.04
3	-8.80	-4.27	4.52
4	-9.31	-4.73	4.58
5	-8.34	-4.17	4.16
6	-9.46	-4.35	5.11
7	-9.04	-4.35	4.69
8	-9.40	-4.64	4.76
9	-8.68	-4.35	4.33
10	-9.31	-4.51	4.80
Average	-9.03	-4.40	4.63

VEP signals with noise reduced by PCA. From the figure, it be seen that PCA has considerably reduced noise effects from the VEP signals. To further validate the ability of PCA to reduce noise, Table 1 lists the SNR values of noise corrupted VEP and noise reduced VEP signals. The table also shows the SNR improvement after using PCA. Due to space constraints, only values from 10 VEP signals are given, but there are improvements in SNR for all the 61 VEP signals.

3. VISUAL EVOKED POTENTIAL DATA

In this section, the experimental set-up used to record the VEP data is discussed. In addition, pre-processing methods to remove VEP signals with eye blink artifact and setting the pre-stimulus baseline of these signals to zero are described. Twenty subjects participated in the experimental study to record the VEP data that consisted of 10 alcoholics and 10 non-alcoholics. The alcoholics are non-amnesic and have been abstinent for a minimum period of one month (through closed ward hospitalisation) and are also off all medications for the same period of time. Most alcoholics have been drinking heavily for a minimum of 15 years and started drinking at approximately 20 years of age. The non-alcoholic subjects are not alcohol or substance abusers.

The subjects are seated in a reclining chair located in a sound attenuated RF shielded room. Measurements are taken from 64[†] channels placed on the subject's scalp, which are sampled at 256 Hz. The electrode positions (as shown in Figure 4) are located at standard sites using extension of Standard Electrode Position Nomenclature, American Encephalographic Association. The signals are band-pass filtered between 0.02 and 50 Hz using analogue filters.

3.1 Snodgrass and Vanderwart Picture Stimuli The VEP data is recorded from subjects while being exposed to a stimulus, which is a picture of an object chosen from Snodgrass and Vanderwart picture set⁽¹⁰⁾. These pictures are common black and white line drawings like airplane, banana, ball, etc. executed according to a set of rules that provide consistency of pictorial representation. The pictures have been standardised on variables of central relevance to memory

[†]In all the experiments in this paper, 3 channels are used as references. Therefore, only 61 channels are used as active channels.

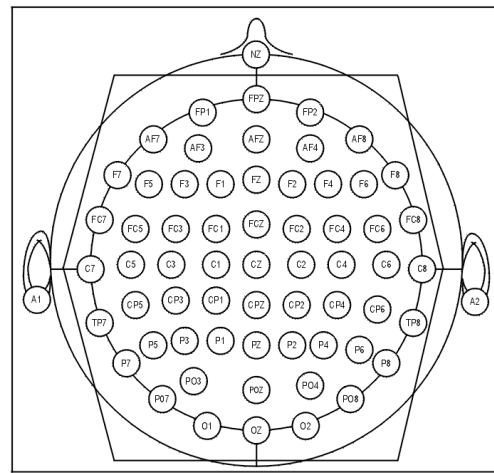

Fig. 4. Electrode positions

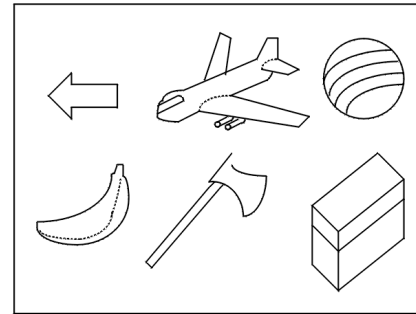

Fig. 5. Some objects from Snodgrass and Vanderwart picture set

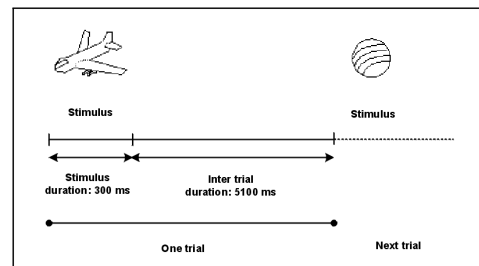

Fig. 6. Example of stimulus presentation

and cognitive processing. These pictures represent different concrete objects, which are easily named i.e. they have definite verbal labels. Figure 5 shows some of these pictures. One-second measurements after each stimulus onset are stored. Stimulus duration of each picture is 300 ms with an inter-trial interval of 5.1 s. The pictures are shown using a computer display unit located 1 meter away from the subject's eyes. Figure 6 shows an illustrative example of the stimulus presentation. For further details of the data collection process, refer to⁽¹²⁾.

3.2 VEP pre-processing A common artifact that corrupts the visual stimulus EEG data is eye blinks. VEP signals with eye blink artifact contamination are removed using a computer program written to detect VEP signals with magnitudes above 100 mV. These VEP signals detected with eye blinks are then discarded from the experimental study and additional trials are conducted as replacements. The threshold

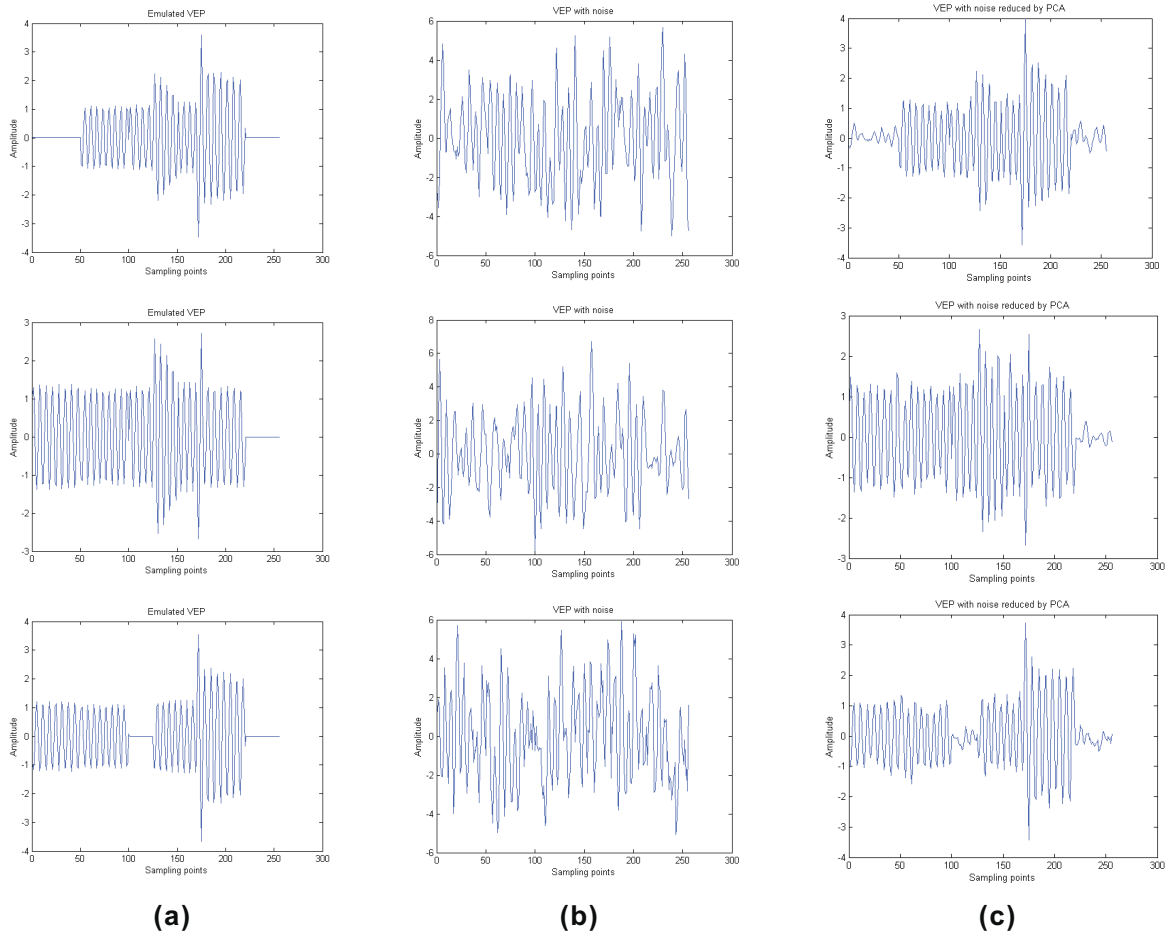

Fig. 3. VEP signals (a) emulated (b) with noise (c) with noise reduced by PCA

value of 100 mV is used since blinking produces 100-200 mV potential lasting 250 milliseconds⁽⁷⁾. Mean from the data are removed. This is to set the pre-stimulus baseline to zero⁽⁹⁾.

4. CLASSIFICATION OF VEP SIGNALS

This section discusses the VEP signal classification by Fuzzy ARTMAP (FA) into two categories: alcoholic and non-alcoholic. The VEP feature extraction is described before describing FA classification. The classification experiments are conducted using the extracted VEP with and without the application of PCA.

4.1 VEP feature extraction A total of 40 artifact free trials for each subject are used in the experimental study giving a total of 800 VEP signals. A 10th order forward and 10th order backward Butterworth digital filter (forward and backward operation to give zero phase response) is used to extract the VEP in the 3-dB passband of 30 to 50 Hz. Order 10 is chosen since it gives a 30-dB minimum stopband at 25 and 55 Hz. Parseval's theorem can now be applied to obtain the equivalent spectral power of the signal, \tilde{x} using

$$SpectralPower = \frac{1}{N} \sum_{n=1}^N [\tilde{x}(n)]^2 \dots\dots\dots (8)$$

where N is the total number of data in the filtered signal. The power values from each of the 61 channels are concatenated into one feature array representing the particular VEP pattern. Figure 7 shows the process of extracting features from VEP signals for the case of using PCA. The VEP feature extraction without the application of PCA is the same as shown in Figure 7 except that PCA is not used.

4.2 Classification These VEP feature arrays are classified by FA into alcoholic and non-alcoholic categories. FA is chosen as compared to other NN due to its high speed training ability in fast learning mode. Half of the patterns are used for training while the rest half are used for testing. FA fast learning weight updates vary with different order of input patterns during training. As such, classification performance will vary. This problem is solved using voting strategy⁽⁴⁾ with 10 runs. FA vigilance parameter (VP) is varied from 0 to 0.9 in steps of 0.1. Figure 8 shows the FA network architecture as used in the experimental study. For further details on FA, refer to⁽⁴⁾ ⁽⁶⁾.

Table 2 shows the results of FA classification with and without the application of PCA for the varying VP values. From the table, it can be seen that FA classification improves considerably with the use of PCA. This is

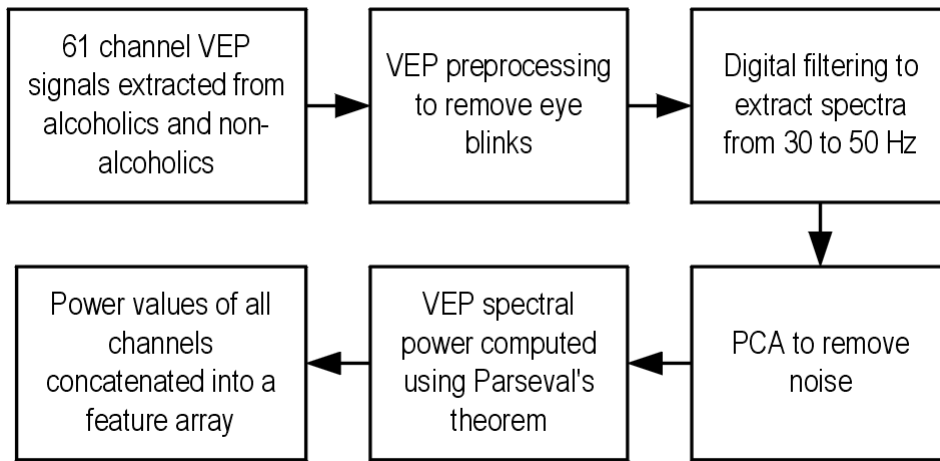

Fig. 7. Example of stimulus presentation

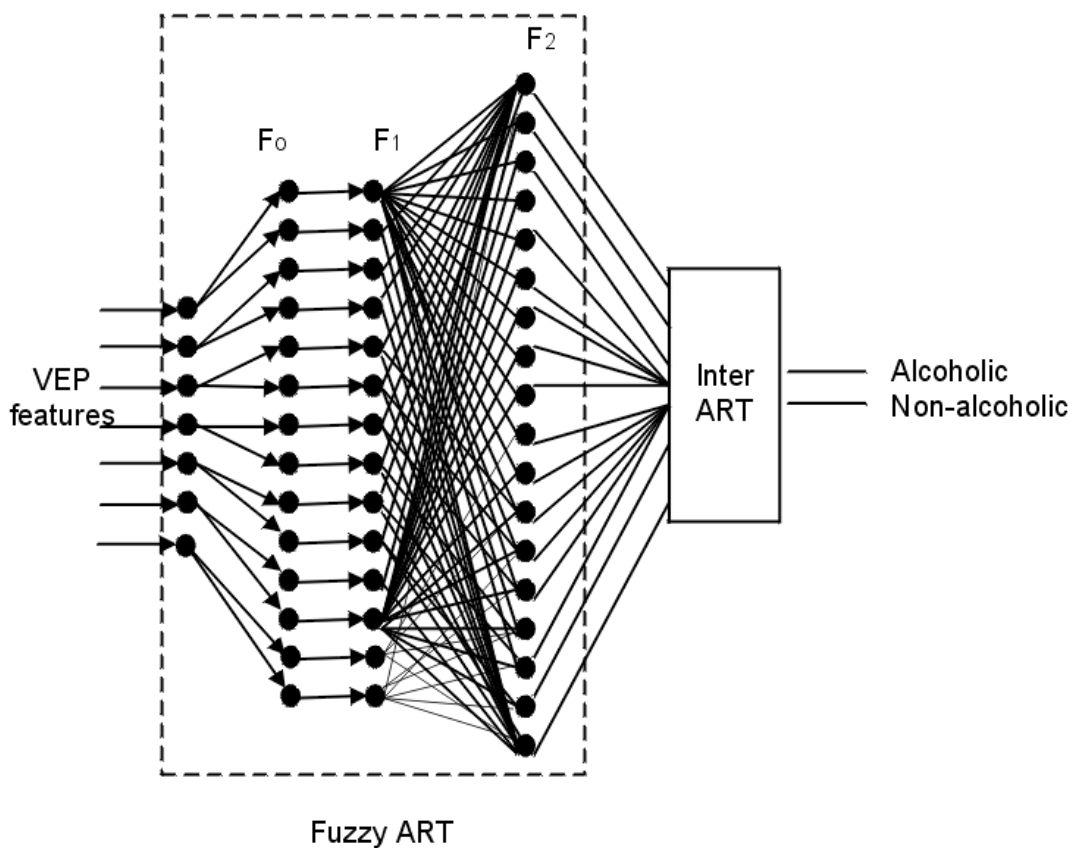

Fig. 8. FA network as used in the study

because of PCA's ability to remove noise from the VEP signals. The best classification using PCA is at 94.75% (VP=0.8) while averaged classification of 92.5% is obtained across all the VP values. The case without using PCA gives lower classification values. Best classification is at 90.25% (VP=0.9) while averaged classification is at 83.33%.

5. CONCLUSION

In this paper, we have applied PCA to reduce noise

from VEP signals. Emulated VEP signals contaminated with noise have been utilised to show the ability of PCA to reduce noise. These noise reduced VEP signals are classified into alcoholics and non-alcoholics category using FA. Gamma band power computed from these VEP signals are used as features by FA. The FA classification results show improvement with the application of PCA to reduce noise in VEP signals as compared to the case without applying PCA. Overall, the good accuracy of FA classification performances indicates that

Table 2. FA classification results

VP	Classification (%)	
	With PCA	Without PCA
0	91.25	80.25
0.1	92.50	82.50
0.2	93.50	81.50
0.3	92.00	81.75
0.4	90.75	83.50
0.5	90.25	81.00
0.6	94.50	83.75
0.7	91.25	84.50
0.8	94.75	84.25
0.9	94.25	90.25
Average	92.50	83.33

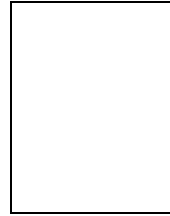

VEP spectral power centred at 40 Hz could be used to classify alcoholics and non-alcoholics.

6. ACKNOWLEDGEMENTS

We thank Professor Henri Begleiter at the Neurodynamics Laboratory at the State University of New York Health Center at Brooklyn, USA who generated the raw ERP data and Mr. Paul Conlon, of Sasco Hill Research, USA for sending the data to us.

(Manuscript received July 20, 7, revised March 9, 13)

References

- (1) Aunon, J.I., McGillem, C.D., and Childers, D.G., "Signal Processing in Event Potential Research: Averaging and Modelling," *CRC Crit. Rev. Bioeng.*, vol. 5, pp. 323-367, 1981.
- (2) Basar, E., Eroglu, C.B., Demiralp, T., and Schurman, M., "Time and Frequency Analysis of the Brain's Distributed Gamma-Band System," *IEEE Engineering in Medicine and Biology Magazine*, pp. 400-410, July/Aug. 1995.
- (3) Begleiter, H., et. al., "Quantitative Trait Loci Analysis of Human Event-related Brain Potentials," *Electroencephalography and Clinical Neurophysiology*, vol.108, pp. 244-250, 1998.
- (4) Carpenter, G.A., Grossberg, S., and Reynolds, J.H., "A Fuzzy ARTMAP Nonparametric Probability Estimator for Nonstationary Pattern Recognition Problems," *IEEE Transactions on Neural Networks*, vol. 6, no. 6, pp. 1330-1336, 1995.
- (5) Jolliffe, I.T., *Principal Component Analysis*, Springer-Verlag, 1986.
- (6) Kasuba, T., "Simplified Fuzzy ARTMAP," *AI Expert*, pp. 19-25, vol. 8, no. 11, 1993.
- (7) Kriss, A., "Recording Technique," in Halliday, A.M. (ed), *Evoked Potentials in Clinical Testing*, Churchill Livingstone, 1993.
- (8) Misulis, K.E., *Spehlmann's Evoked Potential Primer: Visual, Auditory and Somatosensory Evoked Potentials in Clinical Diagnosis*, Butterworth-Heinemann, 1994.
- (9) Polich, J., "P300 in Clinical Applications: Meaning, Method and Measurement," *American Journal of EEG Technology*, vol.31, pp. 201-231, 1991.
- (10) Snodgrass, J.G., and Vanderwart, M., "A Standardized Set of 260 Pictures: Norms for Name Agreement, Image Agreement, Familiarity, and Visual Complexity," *Journal of Experimental Psychology, Human Learning and Memory*, vol. 6, no.2, pp. 174-215, 1980.
- (11) Tallon-Baudry, C., Bertrand, O., Delpuech, C., and Pernier, J., "Stimulus Specificity of Phased- Locked and Non-Phase Locked 40 Hz Visual Responses in Human," *The Journal of Neuroscience*, vol. 16, no. 13, pp. 4240-4249, 1996.
- (12) Zhang, X.L., Begleiter, H., Porjesz, B., and Litke, A., "Electrophysical Evidence of Memory Impairment in Alcoholic Patients," *Biological Psychiatry*, vol. 42, 1157-1171, 1997.